



DPW | SOLAR



PREFORMED LINE PRODUCTS

TOP-OF-POLE MOUNTS

Photovoltaic Module Mounting Structures

chosen by professionals...

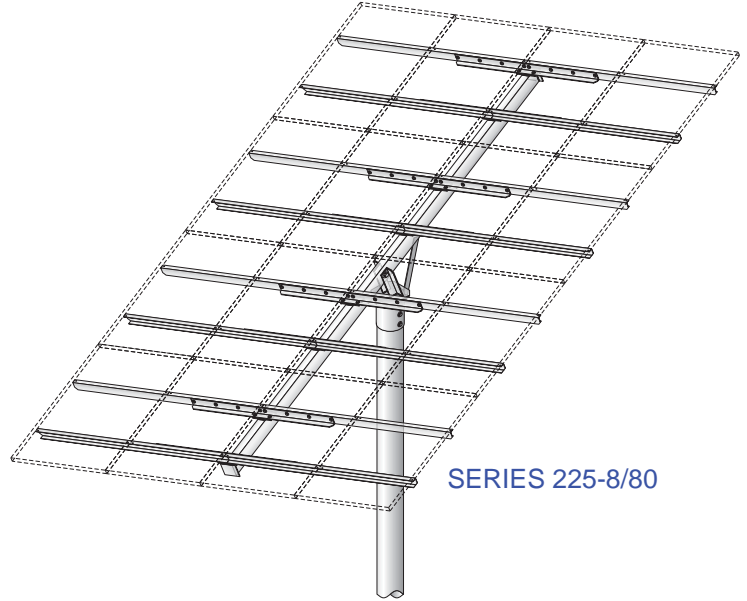

SERIES 225-8/80

...favored by experienced installers for over 12 years.

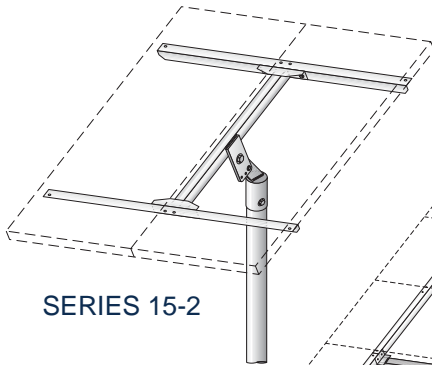

SERIES 15-2

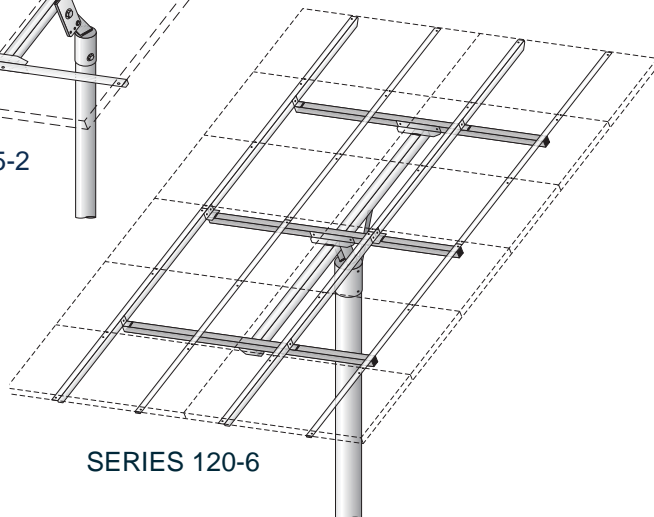

SERIES 120-6



POWER-FAB products are manufactured by
DIRECT POWER AND WATER CORP.,
a division of **Preformed Line Products,**



Features and Specifications

DESIGN

POWER-FAB Top-of-Pole Mounts, manufactured by Direct Power and Water Corporation, are available in several sizes ranging from 1-module through 24-modules -- up to 260 square feet. The rack design is determined by the area of the module(s) to be mounted, not necessarily the number of modules.



SERIES 120-6

POWER-FAB Top-of-Pole mounts are designed for maximum strength and ease of installation. Our racks are module-specific and not universal, which helps to reduce the number of parts. This simplifies assembly and minimizes assembly errors.

No aluminum components are threaded to be attached to other components. All of our mounting sleeves are heavy gauge steel and have fully welded caps. Hardened bolts are used to lock the mounting sleeve to the pole.

MODULE-SPECIFIC DESIGN

Using a module-specific design allows us to build racks with the fewest number of parts. All racks are made to fit the specific module that is to be mounted. This ensures that

the system is assembled in just the manner it is intended. No measuring or guesswork is required. All the

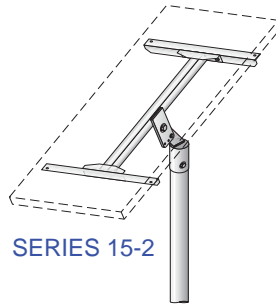

SERIES 15-2

holes are located exactly where needed. Gaps between modules are minimal and uniform. There will never be excess rack material extending beyond the modules.

MATERIALS

Strongbacks, Elevation Pivots, and Mounting Sleeves are made of heavy gauge steel flat bar, square tubing, and pipe or mechanical tubing conforming to ASTM A36 and ASTM A500-Grade B. All parts are mig-welded, burrs are removed, corners are coped, and edges are sanded. All steel parts are coated with two coats of industrial urethane enamel paint.

Solar module mounting rails are made of mill-finish 6061-T6 structural aluminum angle or channel. All holes are deburred, and edges are coped and sanded. Stainless steel module mounting hardware is provided with each rack. Standard rack assembly hardware is zinc-plated Grade 5. A stainless steel hardware upgrade is optional. (See back page.)

ELEVATION ADJUSTMENT

All standard Top-of-Pole Mounts have six tilt-angle settings from 15° to 65° in 10° increments. The elevation adjustment is positive locking in each position eliminating the possibility of slippage. The racks are balanced about the pivot bolt to make elevation adjustments easy. Other tilt combinations and racks welded at fixed angles are offered as options.

WINDLOADING CAPABILITY

Standard mounts are

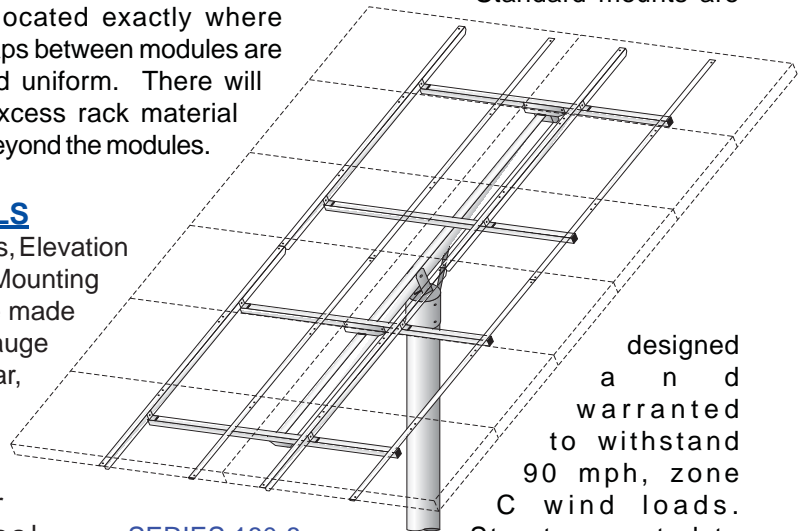

SERIES 180-8

designed and warranted to withstand 90 mph, zone C wind loads.

Structures rated to withstand 130 mph wind loads are available. To specify the High Wind Version, add "-HWV" to the end of the part #.

POLE MOUNTING

All racks have sleeves sized to slip over readily available standard sizes of installer-supplied SCH40 (Schedule 40) steel pipe. The largest mounts (225 ft² and above) mount on SCH 80 steel pipe. The mounting sleeves have set-bolts spaced 90° apart to firmly secure the rack to the pole.

What our dealers say about our racks:

"They are far superior to what I was using. I will make sure to specify your racks from now on. My installer was very impressed."

| Model # | DP-TPM1- | DP-TPM2- | DP-TPM3- | DP-TPM4- | DP-TPM6- | DP-TPM8- | DP-TPM9- | DP-TPM10- | DP-TPM12- | DP-TPM14- | DP-TPM16- | DP-TPM18- |
|--------------------|------------|--------------|--------------|-------------|--------------|--------------|--------------|--------------|-----------------|-----------------|-----------------|-----------------|
| BP | | | | | | | | | | | | |
| BP350/365* | \$155 15-2 | \$165 15-2 | \$325 20-2.5 | \$345 28-3 | \$535 60-4 | \$635 60-4 | -- | \$980 90-6 | \$1155 120-6 | \$1275 120-6 | \$1485 120-6 | -- |
| BP380 | \$155 15-2 | \$165 15-2 | \$325 20-2.5 | \$345 28-3 | \$535 60-4 | \$635 60-4 | -- | \$980 90-6 | \$1155 120-6 | \$1275 120-6 | \$1485 120-6 | -- |
| BP125 | \$160 15-2 | \$310 20-2.5 | \$365 28-3 | \$550 60-4 | \$715 60-4 | \$1090 90-6 | \$1220 100-6 | \$1275 120-6 | \$1400 120-6 | \$1850 160-8 | \$2240 180-8 | \$2440 200-8/80 |
| BP160/175 | \$160 15-2 | \$345 28-3 | \$530 45-4 | \$610 60-4 | \$985 90-6 | \$1320 120-6 | \$1570 130-6 | \$1810 160-8 | \$2180 175-8 | \$2400 225-8/80 | \$2885 225-8/80 | \$3280 260-8/80 |
| BP200 | \$175 15-2 | \$380 28-3 | \$585 45-4 | \$670 60-4 | \$1085 90-6 | \$1390 120-6 | \$1650 130-6 | \$1900 160-8 | \$2290 225-8 | \$2525 225-8/80 | \$3030 225-8/80 | \$3450 260-8/80 |
| CANADIAN S. | | | | | | | | | | | | |
| CS6P190/200 | \$180 15-2 | \$395 35-3 | \$590 55-4 | \$710 70-4 | \$1220 110-6 | \$1600 140-6 | \$1775 155-8 | \$2275 180-8 | \$2485 225-8/80 | \$3265 245-8/80 | -- | -- |
| DAY 4 | | | | | | | | | | | | |
| 180/190-48MC | \$170 15-2 | \$370 28-3 | \$535 45-4 | \$645 60-4 | \$1035 90-6 | \$1390 120-6 | \$1645 130-6 | \$1910 160-8 | \$2290 175-8 | \$2520 225-8/80 | \$3025 225-8/80 | \$3445 260-8/80 |
| EVERGREEN | | | | | | | | | | | | |
| ES-195 | \$180 15-2 | \$398 28-3 | \$590 55-4 | \$710 70-4 | \$1220 110-6 | \$1600 140-6 | \$1775 155-8 | \$2275 180-8 | \$2485 225-8/80 | \$3265 245-8/80 | \$3695 265-8/80 | -- |
| ES-A-200 | \$180 15-2 | \$395 28-3 | \$590 55-4 | \$720 70-4 | \$1220 110-6 | \$1600 140-6 | \$1775 155-8 | \$2275 180-8 | \$2485 225-8/80 | \$3265 245-8/80 | \$3695 265-8/80 | -- |
| GE | | | | | | | | | | | | |
| GE173/200 | \$170 15-2 | \$370 28-3 | \$530 45-4 | \$645 60-4 | \$1035 90-6 | \$1390 120-6 | \$1645 130-6 | \$1900 160-8 | \$2290 175-8 | \$2520 225-8/80 | \$3030 225-8/80 | \$3445 260-8/80 |
| KANEKA | | | | | | | | | | | | |
| GSA60 | \$170 15-2 | \$330 20-2.5 | \$380 28-3 | \$580 35-3 | \$750 60-4 | \$1045 -6 | \$1290 - 6" | \$1340 6" | \$1470 6" | \$1940 8" | \$2250 8" | \$2450 8" |
| KYOCERA | | | | | | | | | | | | |
| KC40/50/65 | \$155 15-2 | \$175 15-2 | -- | \$3355 28-3 | \$480 28-3 | \$640 60-4 | -- | \$930 60-4 | \$1075 120-6 | -- | -- | -- |
| KC85 | \$160 15-2 | \$190 15-2 | \$335 20-2.5 | \$365 28-3 | \$590 60-4 | \$670 60-4 | -- | \$1035 90-6 | \$1215 120-6 | \$1340 120-6 | \$1555 120-6 | -- |
| KC130 / KD135 | \$155 15-2 | \$295 20-2.5 | \$365 28-3 | \$525 60-4 | \$680 60-4 | \$955 90-6 | \$1170 100-6 | \$1215 120-6 | \$1335 120-6 | \$1765 160-8 | \$2140 180-8 | \$2330 200-8/80 |
| KC175 / KD180 | \$170 15-2 | \$370 28-3 | \$530 45-4 | \$645 60-4 | \$1035 90-6 | \$1390 120-6 | \$1645 130-6 | \$1900 160-8 | \$2300 175-8 | \$2525 225-8/80 | \$3025 225-8/80 | \$3545 260-8/80 |
| KC200 / KD210 | \$170 15-2 | \$370 28-3 | \$530 45-4 | \$680 60-4 | \$1085 90-6 | \$1460 120-6 | \$1645 130-6 | \$1990 160-8 | \$2400 175-8 | \$2650 225-8/80 | \$3305 225-8/80 | \$3645 260-8/80 |
| MITSUBISHI | | | | | | | | | | | | |
| MFI20-EC3 | \$155 15-2 | \$300 20-2.5 | \$345 28-3 | \$525 60-4 | \$680 60-4 | \$955 90-6 | \$1170 100-6 | \$1215 120-6 | \$1335 120-6 | \$1765 160-8 | \$2140 180-8 | \$2300 200-8/80 |
| UE125-MF5N | \$160 15-2 | \$315 20-2.5 | \$390 28-3 | \$555 60-4 | \$710 60-4 | \$985 90-6 | \$1220 100-6 | \$1290 120-6 | \$1375 120-6 | \$1810 160-8 | \$2190 180-8 | \$2420 200-8/80 |
| UD185MF5 | \$160 15-2 | \$345 28-3 | \$505 45-4 | \$610 60-4 | \$985 90-6 | \$1320 120-6 | \$1570 130-6 | \$1810 160-8 | \$2180 175-8 | \$2400 225-8/80 | \$2885 225-8/80 | \$3280 260-8/80 |
| REC | | | | | | | | | | | | |
| REC210 | \$180 15-2 | \$395 35-3 | \$590 55-4 | \$710 70-4 | \$1220 110-6 | \$1600 140-6 | \$1775 155-8 | \$2275 180-8 | \$2485 225-8/80 | \$3265 245-8/80 | -- | -- |
| SANYO | | | | | | | | | | | | |
| SY190-DA1 | -- | \$345 28-3 | -- | \$610 60-4 | \$985 90-6 | \$1320 120-6 | -- | \$2080 160-8 | \$2510 175-8 | \$2760 225-8/80 | \$3320 225-8/80 | -- |
| SY200-BA19 | \$160 15-2 | \$345 28-3 | \$505 45-4 | \$610 60-4 | \$985 90-6 | \$1320 120-6 | \$1570 130-6 | \$1810 160-8 | \$2180 175-8 | \$2400 225-8/80 | \$2885 225-8/80 | \$3280 260-8/80 |
| SY215-NKHA5 | \$160 15-2 | \$345 28-3 | \$505 45-4 | \$610 60-4 | \$985 90-6 | \$1320 120-6 | \$1570 130-6 | \$1810 160-8 | \$2180 175-8 | \$2400 225-8/80 | \$2885 225-8/80 | \$3280 260-8/80 |
| SHARP | | | | | | | | | | | | |
| SHP80 | \$155 15-2 | \$165 15-2 | \$325 20-2.5 | \$345 28-3 | \$540 60-4 | \$635 60-4 | -- | \$980 90-6 | \$1155 120-6 | \$1275 120-6 | \$1485 120-6 | -- |
| SHP123 / 130 | \$155 15-2 | \$300 20-2.5 | \$345 28-3 | \$525 60-4 | \$680 60-4 | \$950 90-6 | \$1170 100-6 | \$1215 120-6 | \$1335 120-6 | \$1765 160-8 | \$2140 180-8 | \$2330 200-8/80 |
| SHP170 / 175 / 180 | \$160 15-2 | \$345 28-3 | \$505 45-4 | \$610 60-4 | \$985 90-6 | \$1320 120-6 | \$1570 130-6 | \$1810 160-8 | \$2180 175-8 | \$2400 225-8/80 | \$2885 225-8/80 | \$3280 260-8/80 |
| SHP198 | \$160 15-2 | \$345 28-3 | \$505 45-4 | \$680 60-4 | \$1085 90-6 | \$1460 120-6 | \$1645 130-6 | \$1990 160-8 | \$2400 180-8 | \$2650 225-8/80 | \$3305 225-8/80 | \$3645 260-8/80 |
| SHP224 | \$180 15-2 | \$395 35-3 | \$590 55-4 | \$710 70-4 | \$1220 110-6 | \$1600 140-6 | \$1775 155-6 | \$2275 180-8 | \$2485 225-8/80 | \$3265 245-8/80 | -- | -- |
| SOLARWORLD | | | | | | | | | | | | |
| SWD75/80 | \$155 15-2 | \$165 15-2 | \$325 20-2.5 | \$345 28-3 | \$535 60-4 | \$635 60-4 | -- | \$980 90-6 | \$1155 120-6 | \$1275 120-6 | \$1485 120-6 | -- |
| SWD175 | \$160 15-2 | \$345 28-3 | \$505 45-4 | \$610 60-4 | \$985 90-6 | \$1320 120-6 | \$1570 130-6 | \$1820 160-8 | \$2180 175-8 | \$2400 225-8/80 | \$2885 225-8/80 | \$3280 260-8/80 |
| SUNPOWER | | | | | | | | | | | | |
| SPR90/95 | \$155 15-2 | \$165 15-2 | \$325 20-2.5 | \$345 28-3 | \$535 60-4 | \$635 60-4 | -- | \$980 90-6 | \$1155 120-6 | \$1275 120-6 | \$1485 120-6 | -- |
| SPR2210/220/230 | \$160 15-2 | \$345 28-3 | \$505 45-4 | \$610 60-4 | \$985 90-6 | \$1320 120-6 | \$1570 130-6 | \$1810 160-8 | \$2180 175-8 | \$2400 225-8/80 | \$2885 225-8/80 | \$3280 260-8/80 |
| SPR305/315 | \$180 15-2 | \$395 35-3 | \$590 55-4 | \$710 70-4 | \$1220 110-6 | \$1600 140-6 | \$1775 155-8 | \$2275 180-8 | \$2485 225-8/80 | \$3265 245-8/80 | -- | -- |
| SUNTECH | | | | | | | | | | | | |
| STP165-180 | \$160 15-2 | \$345 28-3 | \$505 45-4 | \$610 60-4 | \$985 90-6 | \$1320 120-6 | \$1570 130-6 | \$1810 160-8 | \$2180 175-8 | \$2400 225-8/80 | \$2885 225-8/80 | \$3280 260-8/80 |
| STP200-210 | \$170 15-2 | \$370 28-3 | \$535 45-4 | \$665 60-4 | \$1035 90-6 | \$1390 120-6 | \$1645 130-6 | \$1910 160-8 | \$2290 180-8 | \$2520 225-8/80 | \$3025 225-8/80 | \$3445 260-8/80 |
| SUNWIZE | | | | | | | | | | | | |
| SWZ50A/55A/60A | \$155 15-2 | \$170 15-2 | \$325 20-2.5 | \$345 28-3 | \$540 60-4 | \$640 60-4 | -- | \$930 90-6 | \$1160 120-6 | \$1275 120-6 | \$1490 120-6 | -- |
| SWZ75A/80A | \$160 15-2 | \$170 15-2 | \$325 20-2.5 | \$345 28-3 | \$545 60-4 | \$650 60-4 | -- | \$980 90-6 | \$1190 120-6 | \$1305 120-6 | \$1525 120-6 | -- |
| SWZ85/90/95 | \$165 15-2 | \$305 20-2.5 | \$360 28-3 | \$425 35-3 | \$625 60-4 | \$1005 90-6 | \$1165 100-6 | \$1080 120-6 | \$1190 120-6 | \$1365 160-8 | \$1685 160-8 | \$1920 180-8 |
| SWZ170/175/180 | \$160 15-2 | \$345 28-3 | \$505 45-4 | \$610 60-4 | \$985 90-6 | \$1320 120-6 | \$1570 130-6 | \$1810 160-8 | \$2180 175-8 | \$2400 225-8/80 | \$2885 225-8/80 | \$3280 260-8/80 |
| YINGLI | | | | | | | | | | | | |
| YL-150-175 | \$170 15-2 | \$370 28-3 | \$535 45-4 | \$645 60-4 | \$1035 90-6 | \$1390 120-6 | \$1645 130-6 | \$1910 160-8 | \$2290 17580-8 | \$2520 225-8/80 | \$3025 225-8/80 | \$3445 260-8/80 |

PRICING - 08/08
 PRICES SUBJECT TO
 CHANGE WITHOUT NOTICE.
 MANUFACTURER RESERVES
 THE RIGHT TO MODIFY
 CALL TO CONFIRM.

SERIES #: To the right of the PRICE is the Series designation. The Series is not a part number. It designates the applicable instructions, the generic design of the rack, and the mounting pole size. It is not a part number but is provided to give general design information and pipe mounting size.

Options And Accessories

| STANDARD MOUNTING POLE | UPGRADE SLEEVE TO FIT ON: | | | | | |
|------------------------|---------------------------|------|------|------|------|-------|
| | | 2.5" | 3" | 4" | 6" | 8" |
| | 2" | \$22 | \$28 | \$35 | \$94 | \$260 |
| | 2.5" | -- | \$25 | \$30 | \$94 | \$245 |
| | 3" | -- | -- | \$28 | \$88 | \$235 |
| | 4" | -- | -- | -- | \$82 | \$230 |
| | 6" | -- | -- | -- | -- | \$205 |

HIGH WIND VERSION for 130 MPH, Class C Wind Zone

For High Wind version add "-HWV" to the end of the part number

Example: TPM12-BP365-HWV

Increase price 25% for the HWV option

FINISH UPGRADE

| | |
|---|---------|
| Powder Coat w/ Mill Finish Module Mounting Rails | Add 35% |
| Hot-Dip Galvanized Steel w/ Anodized Module Rails | Add 80% |
| Stainless Steel Construction w/ Anodized Module Rails | CALL |

TAMPER-RESISTANT HARDWARE PACKAGE

| # Modules | 1 | 2 | 4 | 6 | 8 | 9 | 10 | 12 | 14 | 16 | 18 |
|------------|------|------|------|------|------|------|------|-------|-------|-------|-------|
| Added Cost | \$22 | \$31 | \$47 | \$62 | \$77 | \$85 | \$77 | \$108 | \$124 | \$139 | \$155 |

The Tamper Resistant Hardware package includes stainless steel pin-in-hex machine screws with nylon-Insert lock nuts. A matching hex-key is also provided with each package.

STAINLESS STEEL HARDWARE PACKAGE

| # Modules | 1 | 2 | 4 | 6 | 8 | 9 | 10 | 12 | 14 | 16 | 18 |
|------------|------|------|------|------|------|------|------|-------|-------|-------|-------|
| Added Cost | \$10 | \$22 | \$38 | \$58 | \$75 | \$85 | \$86 | \$122 | \$131 | \$156 | \$172 |

The Stainless Steel Hardware Package includes 100% stainless hardware for the structure.

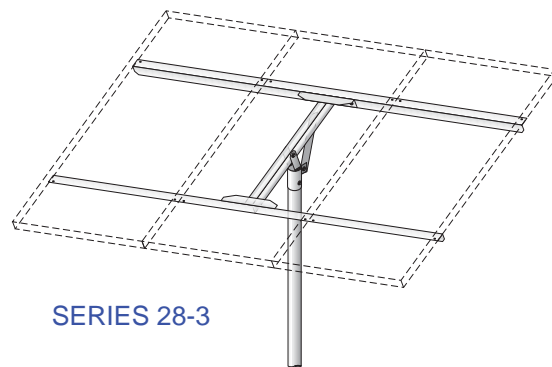

SERIES 28-3

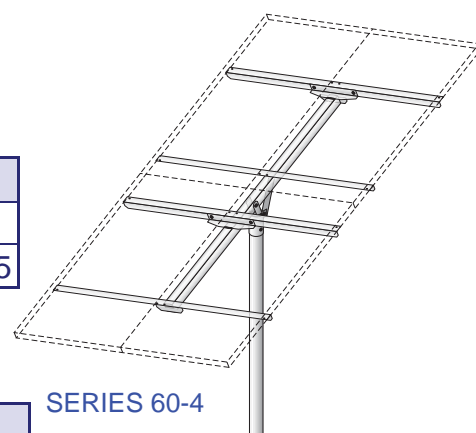

SERIES 60-4



SERIES 90-6

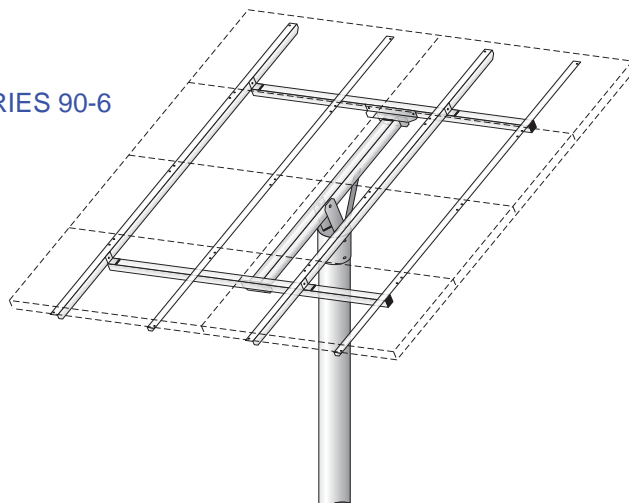

POWER-FAB products include:

| | |
|-----------------------------------|--------------------------------------|
| Top-of-Pole Mounts | Power-Beam Commercial Racking System |
| Side-of-Pole Mounts | Power-Rail Top-Clamp Mounting System |
| Roof/Ground Mounts | Multi-Pole Mount Mounting System |
| Battery Boxes, Racks and Cabinets | Custom Battery Enclosures |

Direct Power and Water Corporation
 A division of Preformed Line Products
 4000-B Vassar Drive NE
 Albuquerque, NM 87107
 PH: 800-260-3792
 Fax: 505-889-3548
 info@power-fab.com
 www.power-fab.com