



Photovoltaic System

**K a n e k a**

**S i l i c o n**

**P V**

"Gift from the Sun"

**канека**

# Kaneka Thin-film Silicon PV Modules

## Powered by Unlimited Solar Energy

Greater actually generated watt-power compared to crystalline silicon PV modules.

Kaneka's amorphous silicon PV module (a-Si) has superior light absorption. Compared to mono-crystalline silicon PV module (c-Si) or poly-crystalline silicon PV module (poly-Si), it generates considerably more power.

### Comparison of total generated watt power per year among various materials

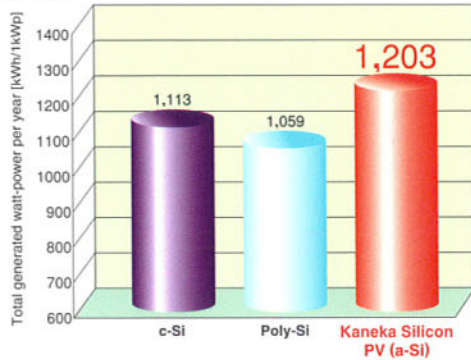

The total solar radiation per year is 1,323kWh/m<sup>2</sup>. Source: "NEDO/Ritsumeikan University Module Field Test and Operational Analysis" presented at the International PV SEC-11, Sapporo, Hokkaido, Japan, 1999. Installation location: Kusatsu, Shiga Prefecture, Japan Slope angle: 15.3 degree.

※NEDO: New Energy and Industrial Technology Organization

Superior performance under high-temperature during summer makes a real difference in actual generated watt-power.

The c-Si PV modules lose some power-generating capability by rises in temperature. But a-Si PV modules generate higher power during summer. The a-Si PV modules can deliver maximum performance during summer when the electricity is needed most for air-conditioners in houses and offices.

### Comparison of total generated watt-power per month among various materials

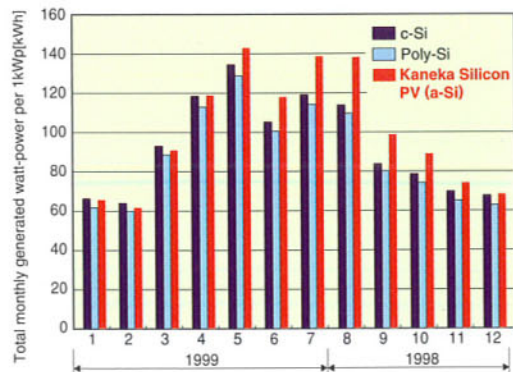

\*Kaneka Silicon PV's generated watt-power is approximately same as that of other crystalline silicon PVs during the winter months, but in summer the Kaneka Silicon PV generates significantly more power compared to other crystalline silicon PVs.

Source: "NEDO/Ritsumeikan University Module Field Test and Operational Analysis" presented at the international PV SEC-11, Sapporo, Hokkaido, Japan, 1999

Installation location: Kusatsu, Shiga Prefecture Japan

Slope angle: 15.3 degree

※NEDO: New Energy and Industrial Technology Organization



Lead-free solder is adopted to reduce environmental load.

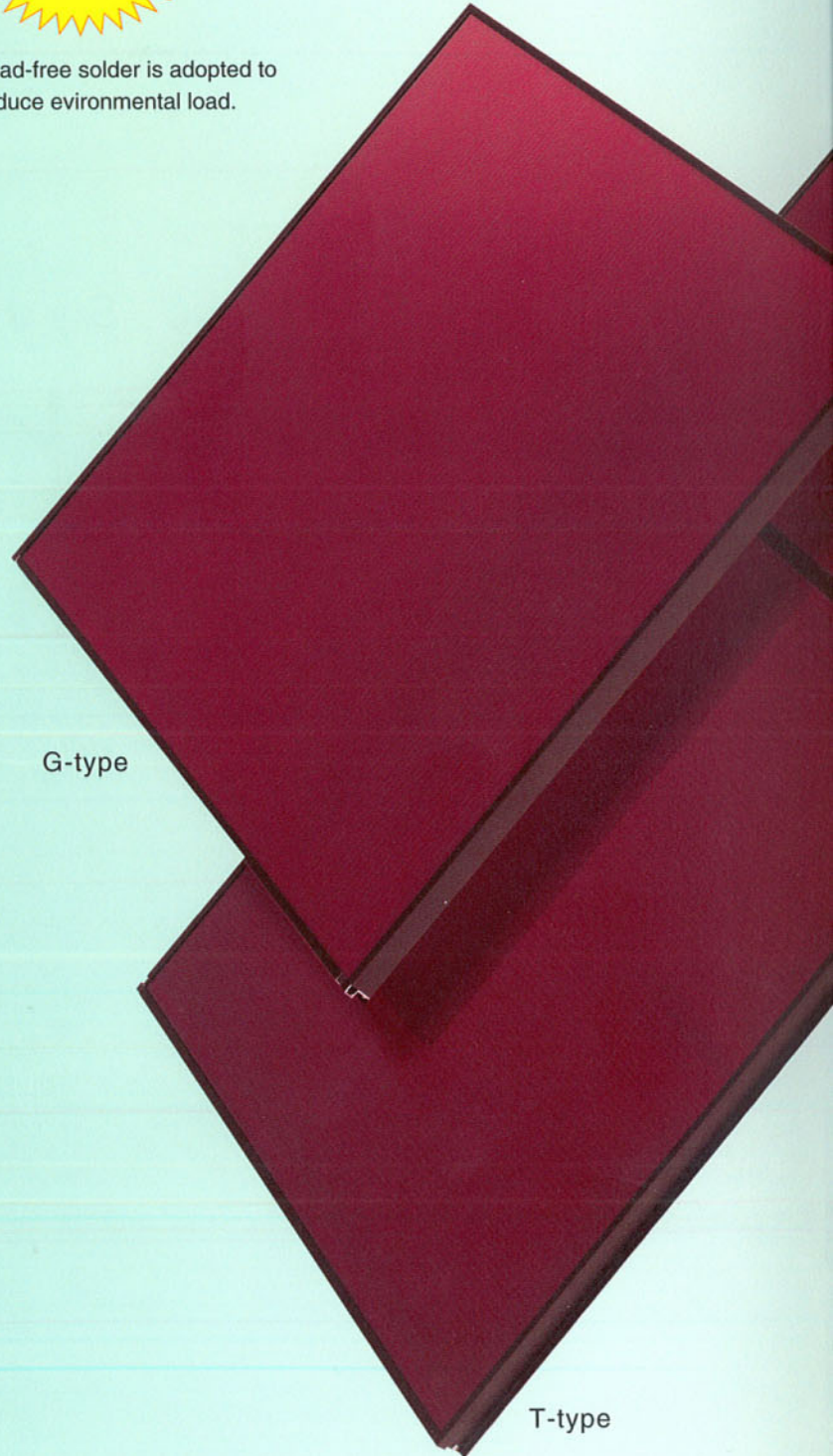



P-type

## Stable power output over long period for outstanding reliability.

The a-Si PV module maintains initial energy conversion efficiency (after full stabilization) over long period, attesting to its outstanding reliability.

- Long-term reliability data for module efficiency after stabilization (JQA acceleration test)

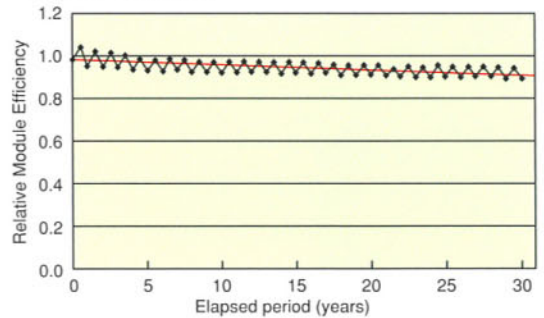

Long-term reliability data for module efficiency after stabilization

Note 1: Data measured by JQA (Japan Quality Assurance Organization) using Kaneka's a-Si PV module as a part of research project subcontracted by NEDO.

Note 2: The acceleration test was performed to evaluate reliability almost over a 30-year period by considering seasonal variations of solar radiation and temperatures.

※NEDO: New Energy and Industrial Technology Organization

## Environmentally Friendly

Another advantage is that the single junction a-Si layer can be made extremely thin. The thickness of a-Si cell is  $0.3\mu\text{m}$ , which is  $1/600$  of that of crystalline silicon cell (approx.  $200\mu\text{m}$ ). This means that a-Si cell uses less material and energy thereby enabling high productivity for mass production.

- Comparison between thin-film a-Si module and c-Si module

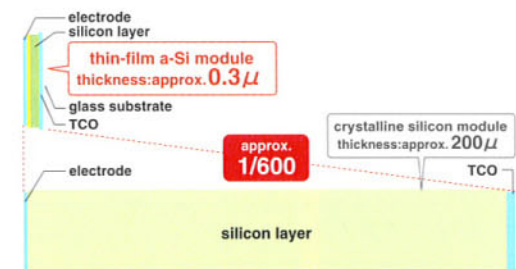

## Shorter Energy Pay-back Time (EPT)

EPT is the time a PV module to "pay back" the energy used in its manufacture by its own power generation.

The EPT of amorphous-Si PV is 1.6 years, which is approximately 6 months shorter than that of crystalline silicon PV (2.2 years)

EPT is one of the most important aspects when evaluating the ecological benefit of PV systems.

- EPT (Energy Pay-back Time)

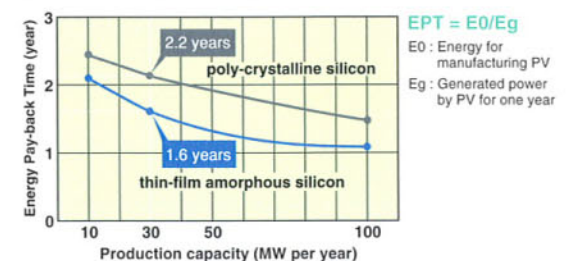

$$EPT = E_0/E_g$$

$E_0$ : Energy for manufacturing PV

$E_g$ : Generated power by PV for one year

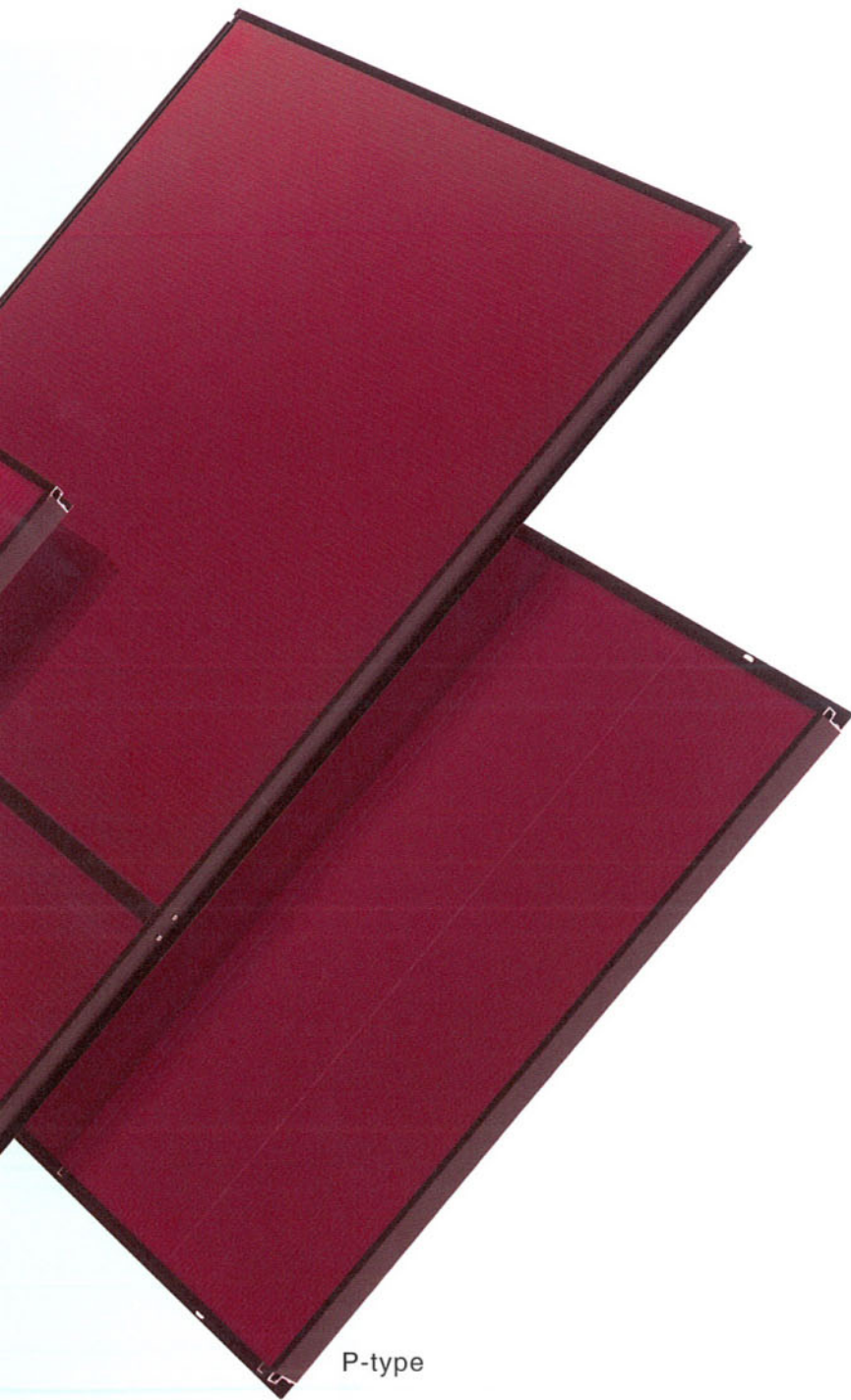

P-type



Germany



Germany

## World Installation Sites



Australia



USA



Netherlands



Cambodia



Japan (See-Through Type)



### 1 IEC Grade ( IEC 61646, Safty Class II (€) )

	G-TYPE	T-TYPE	
Model	G-EA060	T-EC120	T-ED120
Nominal Power (W)	60.0	120.0	120.0
Open Circuit Voltage (V)	91.8	91.8	91.8
Short Circuit Current (A)	1.19	2.38	2.38
Maximum Power Voltage (V)	67.0	67.0	67.0
Maximum Power Current (A)	0.90	1.80	1.80
Maximum System Voltage (V)	530	530	530
Dimensions (mm)	L960×W990×D40	L1918.8×W990×D46	L960×W1978.8×D46
Weight (kg)	13.7	27.5	27.0
Connector	MC	MC	MC

### 2 UL Grade ( cUL LISTED US CEC Registered )

	G-TYPE	T-TYPE	
Model	G-SA060	T-SC120	T-SD120
Nominal Power (W)	60.0	120.0	120.0
Open Circuit Voltage (V)	91.8	91.8	91.8
Short Circuit Current (A)	1.19	2.38	2.38
Maximum Power Voltage (V)	67.0	67.0	67.0
Maximum Power Current (A)	0.90	1.80	1.80
Maximum System Voltage (V)	530	530	530
UL Fire Rating	Class C	Class C	Class C
Fuse Rating (A)	7.0	7.0	7.0
Dimensions (mm)	L960×W990×D40	L1918.8×W990×D46	L960×W1978.8×D46
Weight (kg)	13.7	27.5	27.0
Connector	MC	MC	MC

### 3 Low Voltage ( IEC 61646, cUL LISTED US )

	P-TYPE
Model	P-LE055
Nominal Power (W)	55.0
Open Circuit Voltage (V)	23.0
Short Circuit Current (A)	4.68
Maximum Power Voltage (V)	16.5
Maximum Power Current (A)	3.33
Maximum System Voltage (V)	49
Dimensions (mm)	L990×W990×D40
Weight (kg)	14.4
Connector	none

### Warranty

● G-TYPE, T-TYPE

#### 25-year power output warranty

G-TYPE, T-TYPE PV modules will maintain more than 80% of minimum rated power for 25 years (based on data from silicon PV modules installed over a month under conditions of 25°C, A.M. 1.5 and 100m W/cm<sup>2</sup>)

● P-TYPE

#### 10-year power output warranty

P-TYPE PV modules will maintain more than 90% of minimum rated power for 10 years (based on data from silicon PV modules installed over a month under conditions of 25°C, A.M. 1.5 and 100m W/cm<sup>2</sup>)

- \* Data listed herewith are standard values measured using the JIS testing method but are not guaranteed values.
- \* The PV systems's power-generating capacity is represented by the total of individual PV module power outputs calculated based on the JIS.
- \* Power output under actual usage conditions can vary depending on the level of solar radiation, installation conditions (directions, angles and ambient conditions), regional climates and temperature.
- \* Specifications are subject to change without notice.
- \* JIS : Japanese Industrial Standards

#### G-EA060/G-SA060

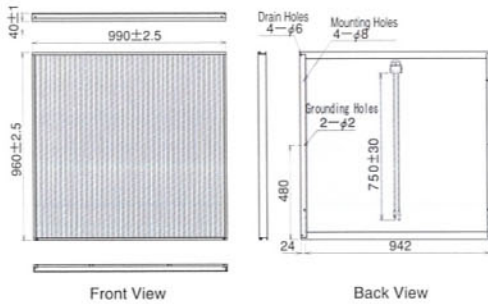

#### P-LE055

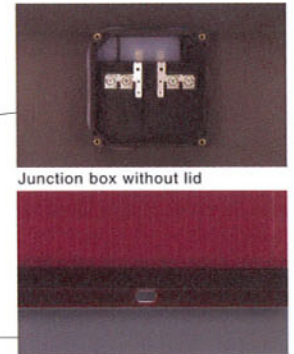
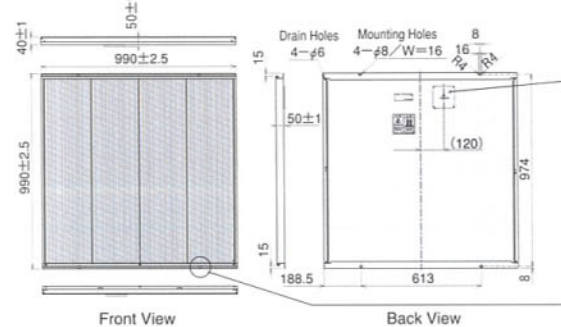

#### T-EC120/T-SC120

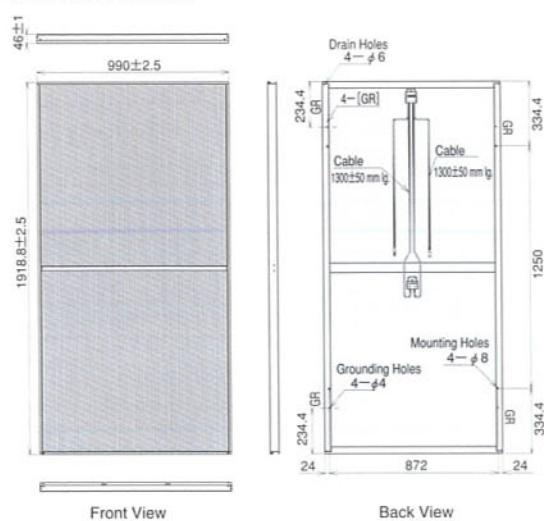

#### T-ED120/T-SD120

