

New Zero Tolerance
Greater Field Performance

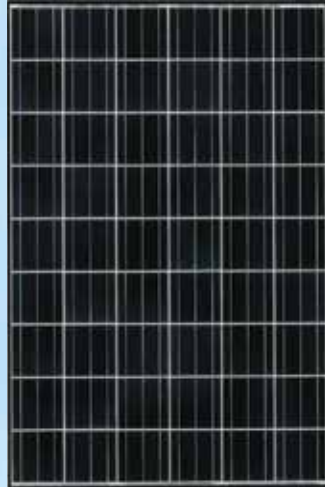

205 WATT

HIGH EFFICIENCY MULTICRYSTAL
PHOTOVOLTAIC MODULE



KD205GX-LPU

NEC 2008 Compliant
UL 1703, Class C
IEC 61215



CUTTING EDGE TECHNOLOGY

As a pioneer with 35 years in solar, Kyocera demonstrates leadership in the development of solar energy products. Kyocera's *Kaizen* Philosophy, commitment to continuous improvement, is shown by repeatedly achieving world record cell efficiencies.

Kyocera Quality Built In:

- New frame technology allows for end mounting with 2400 Pa (50 psf) or wind speeds of 130 mph (ASTM E1830) and traditional mounting with 5400 Pa (113 psf) to support increased snow load
- UV stabilized, aesthetically pleasing black anodized frame
- Supported by major mounting structure manufacturers
- Easily accessible grounding points on all four corners for fast installation
- Proven junction box technology
- Quality locking plug-in connectors to provide safe & quick connections

Kyocera manufactures and assembles solar cells and modules at its own worldwide production sites using a true vertical integration process. This superior approach gives Kyocera complete control over every step of the manufacturing process, producing modules with the industry's tightest power tolerance, promising high quality and efficiency.

- Superior Built-In Quality
- Proven Superior Field Performance
- Tight Power Tolerance
- 25 Year Warranty
- 2 Year Workmanship Warranty



KD205GX-LPU

ELECTRICAL CHARACTERISTICS

Current-Voltage characteristics of Photovoltaic Module KD205GX-LPU at various cell temperatures

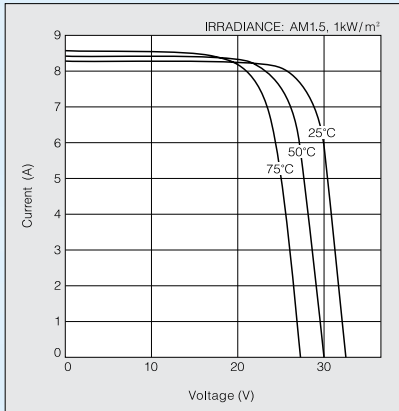

Current-Voltage characteristics of Photovoltaic Module KD205GX-LPU at various irradiance levels

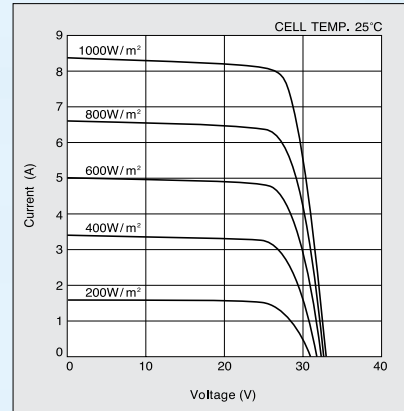

SPECIFICATIONS

Physical Specifications

Unit : mm (in.)

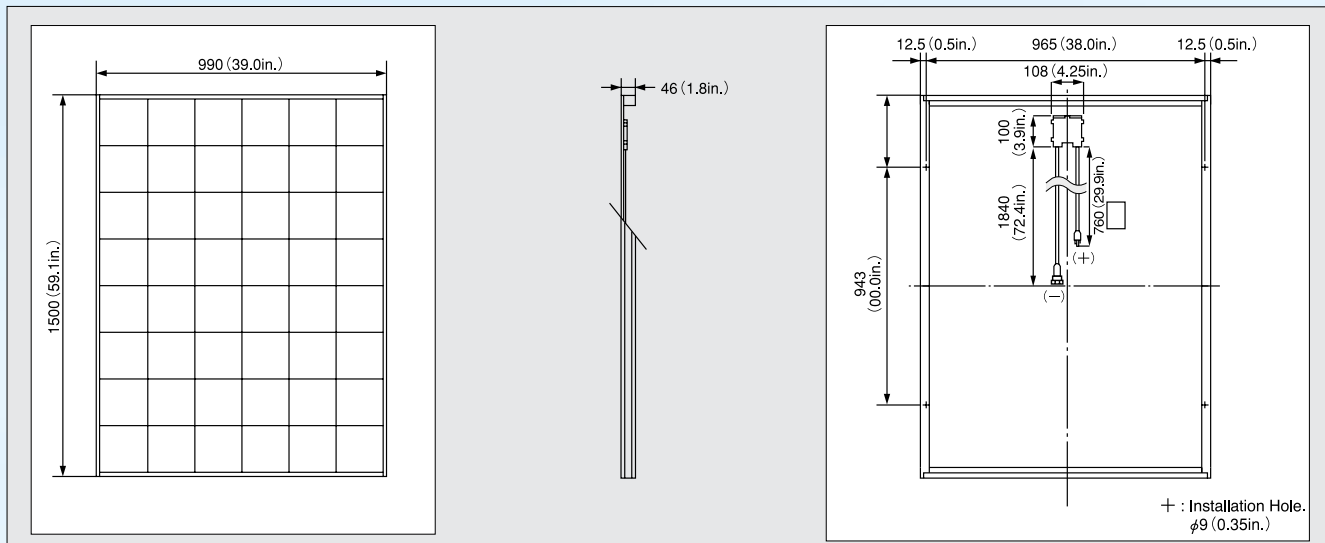

Specifications

Electrical Performance under Standard Test Conditions (*STC)

Maximum Power (P _{max})	205W (+5W/-0W)
Maximum Power Voltage (V _{mpp})	26.6V
Maximum Power Current (I _{mp})	7.71A
Open Circuit Voltage (V _{oc})	33.2V
Short Circuit Current (I _{sc})	8.36A
Max System Voltage	600V
Temperature Coefficient of Voc	-1.20×10 ⁻¹ V/°C
Temperature Coefficient of I _{sc}	5.02×10 ⁻³ A/°C

*STC : Irradiance 1000W/m², AM1.5 spectrum, cell temperature 25°C

Electrical Performance at 800W/m², *NOCT, AM1.5

Maximum Power (P _{max})	145W
Maximum Power Voltage (V _{mpp})	23.6V
Maximum Power Current (I _{mp})	6.17A
Open Circuit Voltage (V _{oc})	30.0V
Short Circuit Current (I _{sc})	6.78A

*NOCT (Nominal Operating Cell Temperature) : 47.9°C

Cells

Number per Module	54
-------------------	----

Module Characteristics

Length × Width × Depth	1500mm(59.1in.)×990mm(39.0in.)×46mm(1.8in.)
Weight	18kg(39.7lbs.)
Cable	(+)760mm(29.9in.),(-)1840mm(72.4in.)

Junction Box Characteristics

Length × Width × Depth	100mm(3.9in.)×108mm(4.3in.)×15mm(0.6in.)
IP Code	IP65

Others

*Operating Temperature	-40°C~90°C
Maximum Fuse	15A

*This temperature is based on cell temperature.

ISO 9001 and ISO 14001 Certified and Registered

www.kyocerasolar.com
800-223-9580 toll free 800-523-2329 fax

